



## **Equipos Profesionales de Limpieza**



### ***Explosivos U90-DC***

# ENS. BARREDORA U-90 DC 00-3396-9

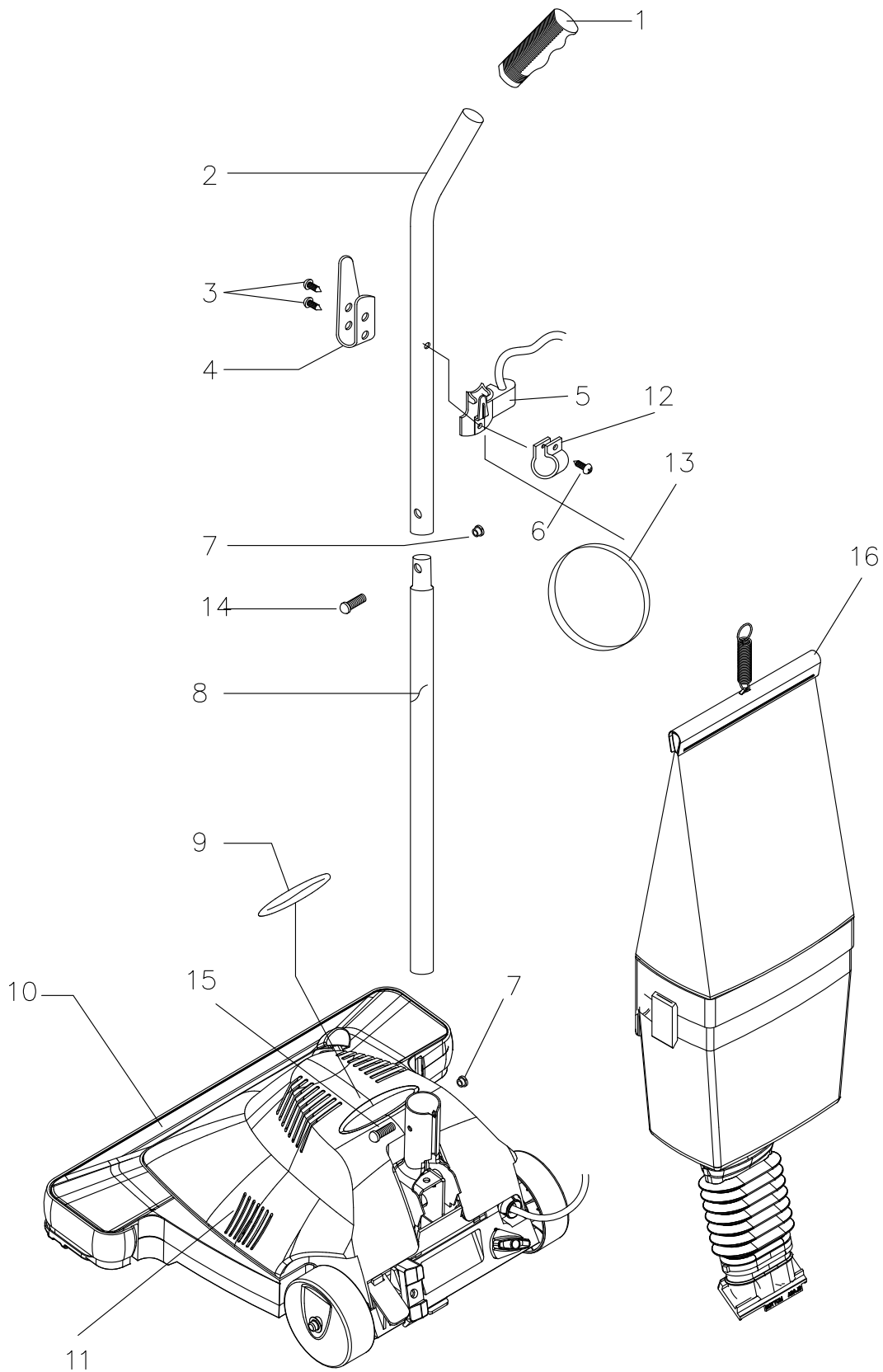



LISTA EXPLOSIONADO PARTES EXTERNAS BARREDORA U-90 DC

No.	No. DE PARTE	DESCRIPCION	CANTIDAD
1	13-0947-5	MANGO ASIDERA	1
2	05-4091-01-2	TUBO SUPERIOR NEGRO U-75	1
3	01-0290-5	PIJA CAB. FIJADORA 10 X 3/8	2
4	05-4089-01-6	GANCHO CORDÓN NEGRO U-75	1
5	13-1462-4	GANCHO PARA CABLE DE LINEA	1
6	01-0283-0	PIJA 8 X ½ CAB. FIJADORA	1
7	02-0141-8	TUERCA SEGURO DE NYLON 10-32	2
8	05-4090-01-4	TUBO INFERIOR NEGRO U-75	1
9	17-4777-01-1	INSERTO CUBIERTA U-75/95	1
10	13-3825-03-4	CHASIS BARREDORA 16" CON TAMPOGRAFIA N	1
11	13-2949-03-3	CUBIERTA PLASTICO C/ TAMPO P/ BARR.	1
12	13-0304-9	RETEN CAB LE	1
13	12-0814-01-7	BANDA 0.250" X 3 7/16"	1
14	01-2034-01-3	TORNILLO ESPECIAL P/MANIJA	1
15	01-2034-5	TORNILLO ESPECIAL P/MANIJA 10-32 X 1 3/4	1
16	46-3626-2	ENS BOLSA DC MASISA	1

ENS. CHASIS BARREDORA U-90 DC

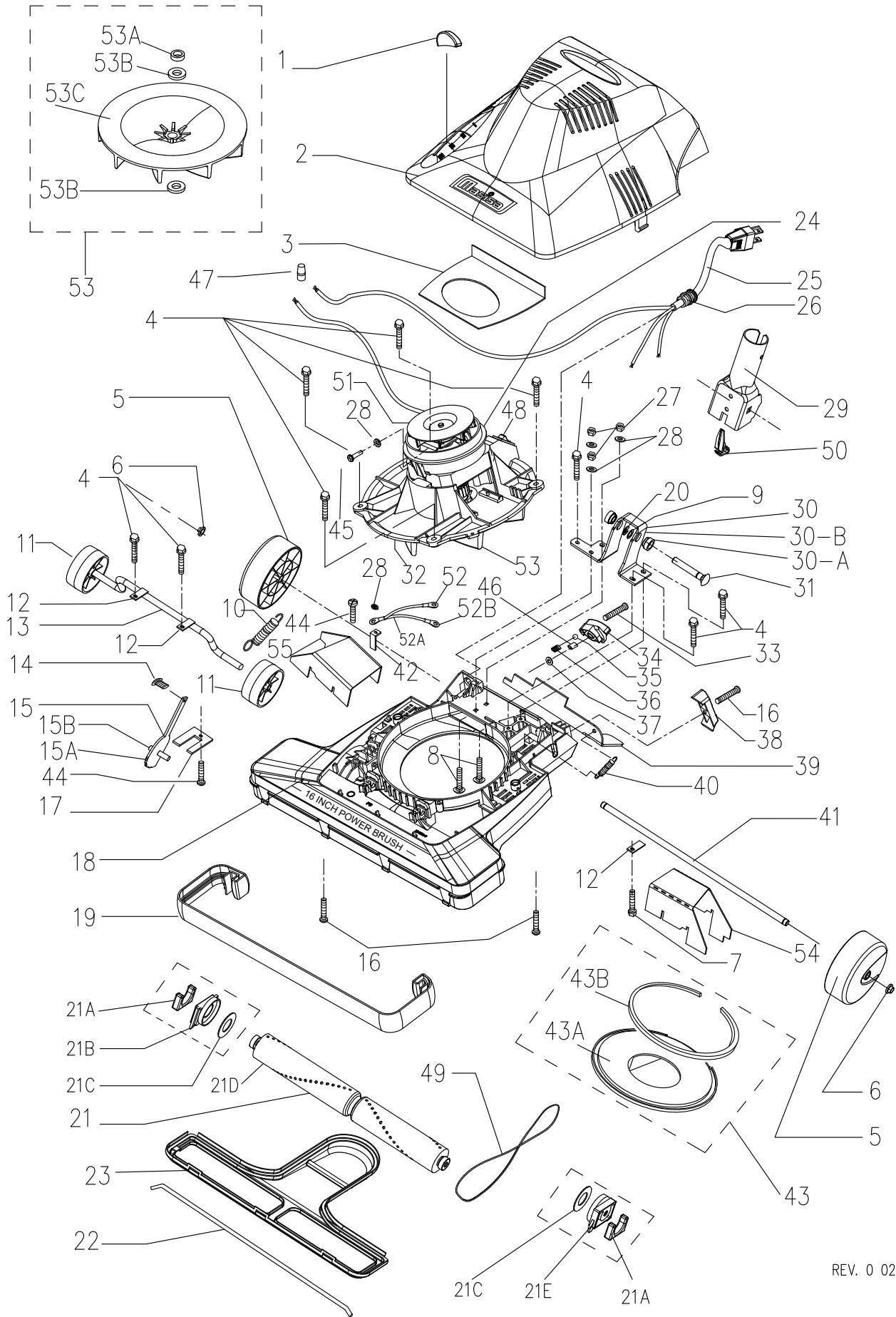



LISTA EXPLOSIONADO PARTES INTERNAS BARREDORA U-90 DC

No.	No. DE PARTE	DESCRIPCION	CANTIDAD
1	13-3147-9	PERILLA LEVA	1
2	13-2949-04-1	CUBIERTA TAMPO. U-80/90 MASISA	1
3	12-0936-0	BAFLE	1
4	01-2174-00-9	322B2713P004-5 TOR. HEX. N12-14 X 5/8	9
5	13-3144-6	RUEDA TRASERA	2
6	04-0671-0	SEGURO CIEGO TIPO SOMBRERO	2
7	01-1499-1	PIJA CAB. HEX NO.10-16x 5/8	1
8	01-0664-1	TORNILLO 10 X 5/8	2
9	04-0589-4	RONDANA PLANA 5/16 X 1/2	1
10	24-0308-7	RESORTE EJE DELANTERO	1
11	13-3143-8	RUEDA DELANTERA	2
12	05-4489-0	PLACA RETEN EJE	3
13	25-1349-02-3	EJE DELANTERO GALVANIZADO	1
14	01-1651-7	PIJA CAB. FIJAJDORA TIPO BT NO.6	1
15	46-3697-3	ENS. LEVA PARA BARREDORA DE PLASTICO	1
15-A	05-5513-6	LEVA BARREDORA	1
15-B	25-1345-5	PERNO PARA LEVA	1
16	01-0093-3	PIJA NO.6X 5/8 TIPO BC/ PHILLIPS PAVONA	2
17	05-4721-6	PLACA RETEN LEVA	1
18	13-3825-03-4	CHASIS BARREDORA 16" CON TAMPOGRAFIA N	1
19	12-0952-7	MOLDURA P/ BARREDORA PLAST.	1
20	04-0469-9	CANDADO DE SEGURIDAD PO-25	1
21	46-2413-6	ENS. RODILLO 16"	1
21-A	12-0522-8	EMPAQUE P/ PORTABALERO	1
21-B	13-1801-3	PORTA BALERO IZQUIERDO	1
21-C	37-0130-7	FIELTRO P/ PORTABALERO	2
21-D	45-0457-7	RODILLO EN CER 16"	1
21-E	13-1252-9	PORTABALERO 11/16	1
22	25-0997-4	VARILLA RETEN TAPA RODILLO	1
23	46-3207-1	ENS. TAPA RODILLO C/ INCLINACION	1
24	13-3146-1	CILINDRO DE ENFRIAMIENTO	1
25	28-1256-8	ENS. CABLE DE LINEA 3" AMARILLO	1
26	12-0953-5	GROMET HEYCO 1232	1
27	02-0041-0	TUERCA HEXAGONAL No.10-24	3
28	04-0271-9	RONDANA ESTRELLA NO. 10X.204	5
29	05-4734-02-5	YUGO CROMADO	1
30	46-3260-0	ENS. SOPORTE YUGO BUJE	1



LISTA EXPLOSIONADO PARTES INTERNAS BARREDORA U-90 DC

No.	No. DE PARTE	DESCRIPCION	CANTIDAD
30-A	13-3148-7	BUJE YUGO	2
30-B	05-4725-7	SOPORTE YUGO	1
31	25-1346-3	PERNO PARA YUGO	1
32	12-0495-01-5	SELLO EMPAQUE BASE MOTOR	1
33	01-0747-4	TORN. C/PHILLISTER 10-32 X 1 1/4	2
34	13-2126-4	PERILLA PARA COPLE BOLSA	1
35	26-0001-3	BALAS CARRETILLA LOCA	1
36	24-0014-1	RESORTE PARA PERILLA DE BARREDORA	1
37	04-0026-7	RONDANA PLANA (02-0101)	1
38	13-2127-2	RETEN P/ COPLE BOLSA	1
39	05-4724-02-6	PEDAL MANIJA GALVÁNZADO	1
40	24-0316-0	RESORTE PEDAL MANIJA BARREDORA	1
41	25-1322-4	EJE RUEDA TRASERO	1
42	05-4993-1	ANGULO PARA TIERRA	1
43	46-3208-9	ENS. TAPA TURBINA C/ SELLO	2
43-A	13-3145-3	TAPA TURBINA	1
43-B	12-0834-01-5	SELLO EMPAQUE TAPA TURBINA BARR. PLASTICO	1
44	01-0270-7	PIJA CAB FIJ PHILLIPS 6 X 3/8" "A"	2
45	01-1683-0	TOR. C /FIJ PH TIPO T 8-32 X 1/4	1
46	05-0997-6	SEPARADOR MOTOR	1
47	10-0137-9	CONECTOR AISLADO GRAPA	1
48	11-0159-01-9	SWITCH BALANCIN LAMB 16 A	1
49	12-0814-01-7	BANDA DE POLIURETANO 0.250 X 3 7/16" 83 A	1
50	13-3273-3	ACTUADOR SWITCH	1
51	46-3099-2	MOTOR BARREDORA ECON C/ FRAME UPPER	1
52	28-1664-3	ENS. CAB LE DE TIERRA	1
52-A	09-1319-4	CABLE VERDE PARA TIERRA	2
52-B	30-0197-1	TERMINAL DE CONEXIÓN A TIERRA	3
53	45-0524-4	KIT TURBINA DE PLASTICO B S/N H	1
53 A	26-0221-7	BUJE P/ TURBINA PLASTICO	1
53 B	04-0123-2	RONDANA DE FIBRA Ø INT. 0.315	2
53 C	13-2442-5	TURBINA 9 ALETAS	1
54	46-3433-3	ENS. ACTUADOR SWITCH-YUGO	1