



Equipos Profesionales de Limpieza



Explosivos abrillantadora de propano 21" y 27"

18 HP 603cc Engine

ITEM NO.	PART NUMBER	DESCRIPTION	QTY.
1	W3132	KAWASAKI FS481V-AS10-M 18H 12V	1
2	W1324	7/8 NYLON HOSE STRAP	2
3	W2606	N51-5A-C-3.0-NT REGULATOR	1
4	W2608	12V A152 LP FUEL LOCKOFF	1
5	W2628	PROPANE CARBURATOR, 603cc ENGINE	1
6	W2648-10.5	3/8 x 10.5" LP350 PSI HOSE W/ REGO MALE FITTINGS	1
7	W2650	REGO COUPLING, FEMALE, RT-HAND	1
8	W2660	HOSE LP 1/2" X 12" 350PSI	1
9	W3305	KAWASAKI BONNET FILTER	1
10	W3311B	BONNET CAGE, FS481	1
11	F62004	5/16 HOSE CLAMP	2
12	F12634-00098	ELBOW, 1/4" MALE NPT TO 1/2" BARB W/ 1/8 FNPT	1
13	F68612	FITTING, CAP, 1/8" MNPT, DRILLED	1
14	F69881	1/4" NPT STREET ELBOW FEM/MALE, BRASS	1
15	F69932	1/2 NPT X 3/8 BARB	1
16	FE17409029909	1/4 TURN OIL DRAIN VALVE	1
17	K11013-7046	ELEMENT AIR FILTER/ FS481V (FOAM PRE-FILTER)	1
18	K11061-7096	GASKET, INSULATOR	2
19	W2804 **	ENVIROGARD V EMISSIONS CONTROL	1
20	K11061-7018	CARBURATOR GASKET, INTAKE FILTER	1
21	K16073-7007	INSULATOR, CARBURETOR	1
22	K92004-7027	DOUBLE THREADED ROD, M6	2
23	K92070-7004	SPARK PLUG	2
24	K99999-0384	ELEMENT AIR FILTER	1
25	K21163-0727	STARTER MOTOR, 12V	1
26	K49065-7007	OIL FILTER	1
27	W1325	NO. 2 POLE OIL PRESSURE SWITCH	1
28	W1305 *	SOLENOID, 12V	1
29	W3240A	MUFFLER W/CAT KA 603cc FH481V	1
29.1	W2803 **	O2 SENSOR	1
30	K11060-7016	GASKET, MUFFLER MANIFOLD	2

* OPTION

** EMISSIONS CONTROL OPTION

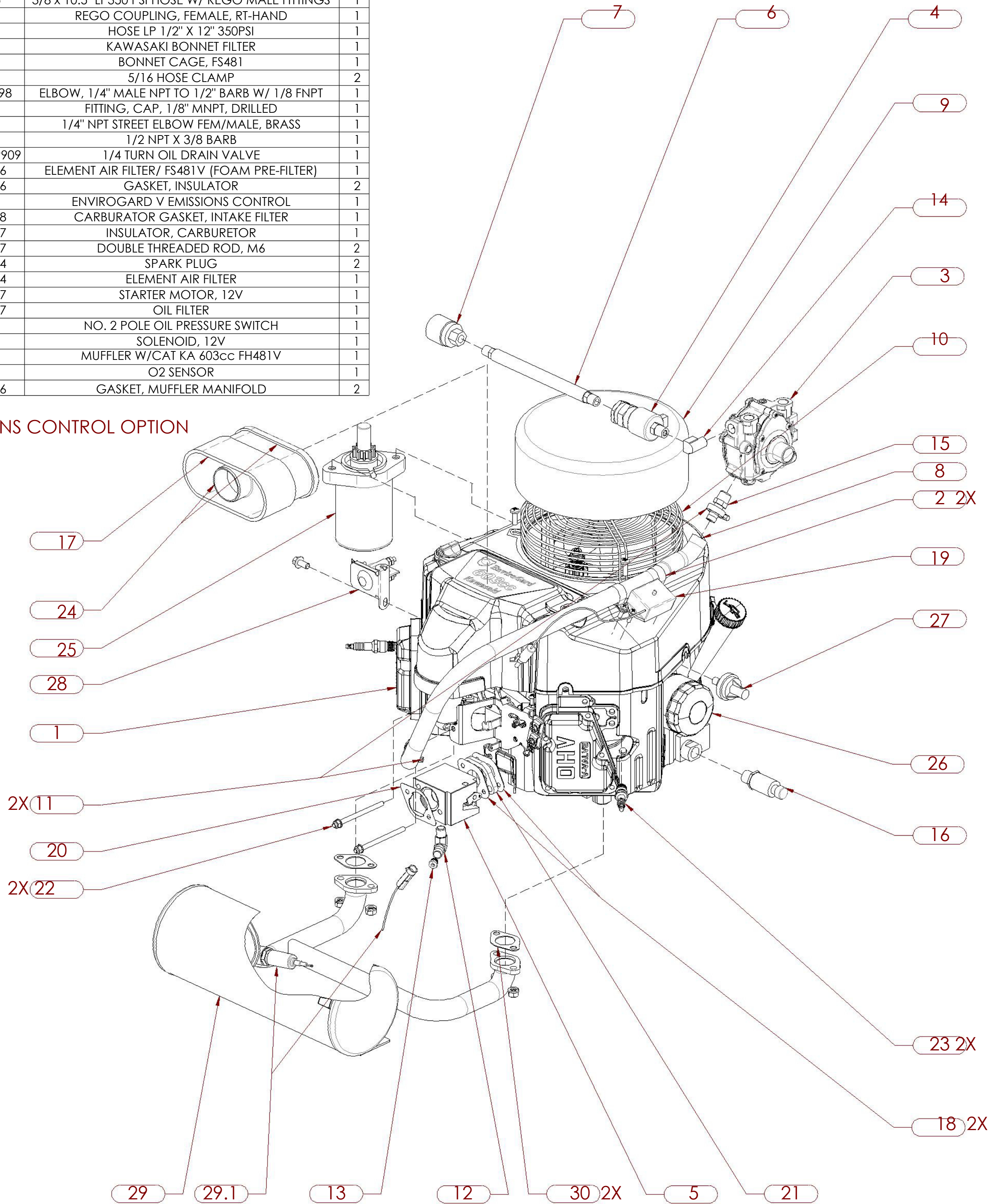

21" Black Diamond

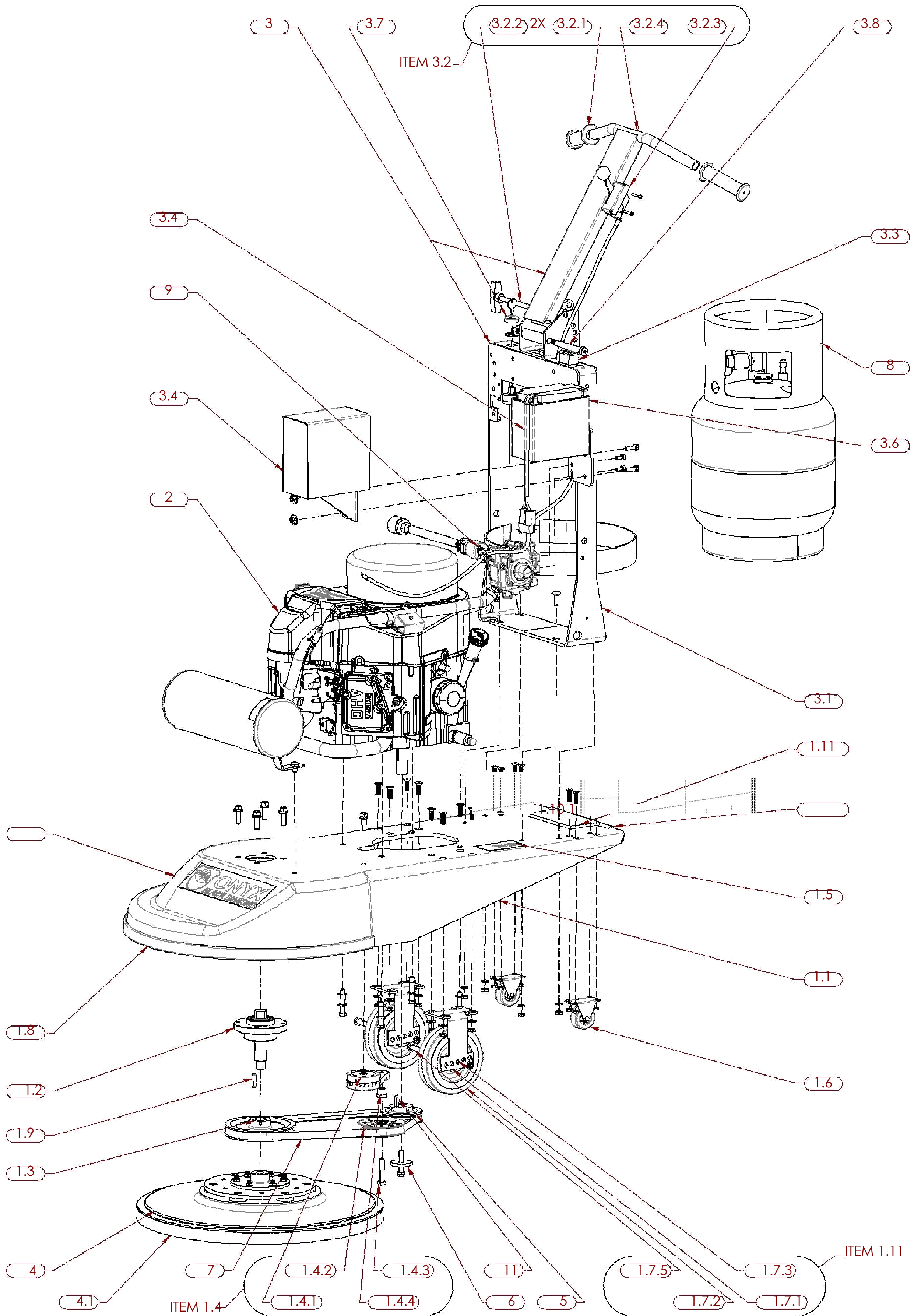

21" Black Diamond

ITEM NO.	PART NUMBER	DESCRIPTION	QTY.
1 *	W5021A	21" BLACK DIAMOND DECK ASSY	1
1.1	W5021	21" FRAME CAST ALUMINUM	1
1.2	W1060A-1	FRONT END BEARING ASSY	1
1.3	W2060	PULLEY 6", BK62	1
1.4	W1101A-C	ROTARY TENSIONER ASSY	1
1.4.1	W1101	ROTARY TENSIONER	1
1.4.2	W1102	ROTARY TENSIONER PULLEY	1
1.4.3	F13111	HEX BOLT, 3/8-16 X 2"	1
1.4.4	W1103	18.7mm x 9.7mm BORE TENSIONER SPACER	1
1.5	W1193	NAME PLATE W/ SERIALIZATION	1
1.6	W4241	REAR CASTER	2
1.7 **	W4210A	DLXE WHEEL BRKT ASSY VAC	2
1.7.1	W4210	DELUXE WHEEL BRACKET (5 HOLE)	1
1.7.2	W4220	RUBBER WHEEL, 6" x 1 1/2"	1
1.7.3	W4218	3/8 " COLSON WHEEL BUSHING	1
1.7.4	F37023	3/8-16 SELF-LOCKING HEX JAM NUT	1
1.7.5	W4221	AXLE FOR COLSON WHEEL	1
1.8	W4108	21" FRONT BUMPER STRIP	1
1.9	F58969	6mm X 32mm PARALLEL KEY	1
1.10	MC8507K24	NEOPRENE RUBBER EDGING	1
1.11	MC93625K95	NATURAL GUM FOAM-ADHESIVE	1
2	W3102-1B	KAWASAKI FS60018HP12V ASSY	1
3 *	W4057A	12V BOTTLE CARRIER ASM.	1
3.1	W4057	BOTTLE CARRIER - VORTEX	1
3.2	W4060-1	T-HANDLE ASSY	1
3.2.1	W4050	HANDLE GRIP FOR T-HANDLE	2
3.2.2	W1454	T-HANDLE PIN W/ LANYARD, 3/8" X 4"	1
3.2.3	W4110	THROTTLE W/ CABLE 53 INCH - WESCON	1
3.2.4	W4060	18" T-HANDLE	1
3.3	W4312	RECTANGULAR HOUR METER	1
3.4	W1302-1	12V BATTERY & WIRE CONNECTOR	1
3.5	W4274	BATTERY BOX	1
3.6	W4359	MBTX 12V12A BATTERY	1
3.7	W1301	IGNITION SWITCH W/ HARDWARE KEY	1
3.8	F26362	SHOULDER BOLT, 1/2" X 4" (3/8-16)	1
3.9	F37024	HEX NUT, SELF-LOCKING, 3/8-16	1
3.10	F33006	FLAT WASHER, WIDE, 5/16"	1
4	W1551A	21" PREMIUM PAD DRIVER ASSY	1
4.1	ON216	21" BURNISHING PAD	1
5	W2035	PULLEY, 3 1/2" BK34-1 W/2 SS	1
6	W1220	CLUTCH WASHER	1
7	WB41	V-GROOVE BELT, 5/8" X 41"	1
8	W2502	PROPANE TNK P#5461TC -20LB.RT	1
9	F0216763	C-LOOP, 1/4"	1
10	MB10	MOTOR SHAFT SPACER	3
11	F58969	6mm X 32mm PARALLEL KEY	1

* ITEMS 1 & 3 ARE INCLUSIVE OF ALL ITEMS BEARING THE RESPECTIVE ITEM NUMBER PREFIX.

** QUANTITIES OF INCLUDED ITEMS ARE AS PER SUBASSEMBLY.

@ ITEM 2 IS DETAILED ON FIRST ILLUSTRATED PARTS SHEET SEPARATELY.

21" Black Diamond with Electric Clutch

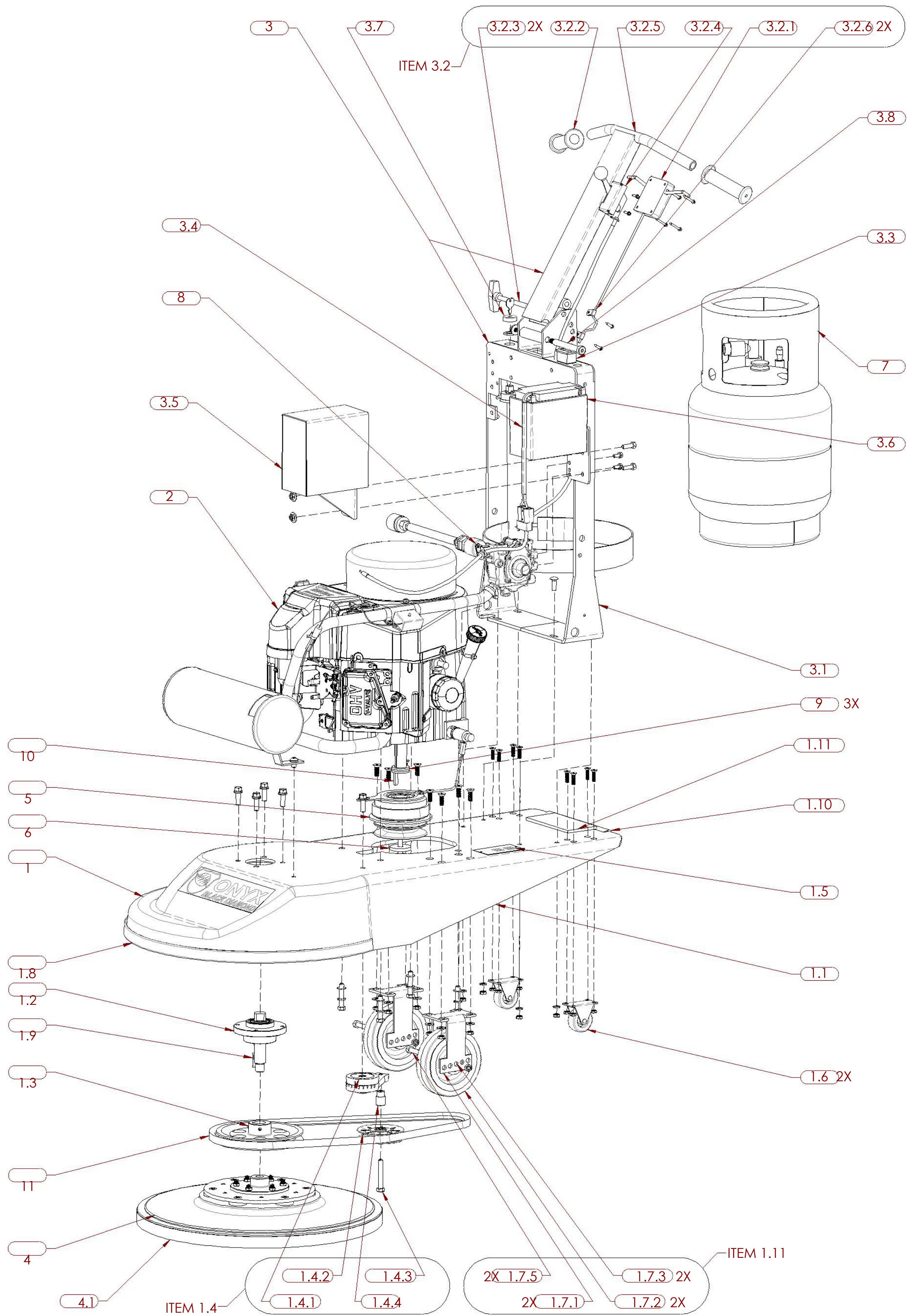

21" Black Diamond with Electric Clutch

ITEM NO.	PART NUMBER	DESCRIPTION	QTY.
1*	W5021A-C	21" BLACK DIAMOND WITH CLUTCH DECK ASSY	1
1.1	W5021	21" FRAME CAST ALUMINUM	1
1.2	W1060A-1	FRONT END BEARING ASSY	1
1.2.1	W1060-1	FRONT END BEARING HOUSING	1
1.2.2	W1055	BEARING 62052RS-C3	2
1.2.3	W1015	SHAFT 1 X 5-1/8	1
1.2.4	F68019	RETAINING RING, EXTERNAL, 1" SHAFT	2
1.3	W2075	PULLEY-7.5" BK77- 1 W/2 SS	1
1.4	W1101A-C	ROTARY CLUTCH TENSIONER ASSY	1
1.4.1	W1101	ROTARY TENSIONER	1
1.4.2	W1102	ROTARY TENSIONER PULLEY	1
1.4.3	13113	HEX BOLT, 3/8-16 X 2 1/2"	1
1.4.4	W1104	31.4mm x 9.7mm BORE TENSIONER SPACER	1
1.5	W1193	NAME PLATE W/ SERIALIZATION	1
1.6	W4241	REAR CASTER	2
1.7**	W4210A	DLXE WHEEL BRKT ASSY VAC	2
1.7.1	W4210	DELUXE WHEEL BRACKET (5 HOLE)	1
1.7.2	W4220	RUBBER WHEEL, 6" x 1 1/2"	1
1.7.3	W4218	3/8" COLSON WHEEL BUSHING	1
1.7.4	F37023	3/8-16 SELF-LOCKING HEX JAM NUT	1
1.7.5	W4221	AXLE FOR COLSON WHEEL	1
1.8	W4108	21" FRONT BUMPER STRIP	1
1.9	F58969	6mm X 32mm PARALLEL KEY	1
1.10	MC8507K24	NEOPRENE RUBBER EDGING	1
1.11	MC93625K95	NATURAL GUM FOAM-ADHESIVE	1
2 @	W3102-1B	KAWASAKI FS60018HP12V ASSY	1
3*	W4057A	12V BOTTLE CARRIER ASM.	1
3.1	W4057	BOTTLE CARRIER - VORTEX	1
3.2	W4060-1	T-HANDLE ASSY	1
3.2.1	W1318A	CLUTCH BOX SWITCH ASSY	1
3.2.2	W4050	HANDLE GRIP FOR T-HANDLE	2
3.2.3	W1454	T-HANDLE PIN W/ LANYARD, 3/8" X 4"	1
3.2.4	W4110	THROTTLE W/ CABLE 53 INCH - WESCON	1
3.2.5	W4060	18" T-HANDLE	1
3.2.6	F0708750	C-LOOP, 3/16"	2
3.3	W4312	RECTANGULAR HOUR METER	1
3.4	W1302-1	12V BATTERY & WIRE CONNECTOR	1
3.5	W4274	BATTERY BOX	1
3.6	W4359	MBTX 12V12A BATTERY	1
3.7	W1301	IGNITION SWITCH W/ HARDWARE KEY	1
3.8	F26362	SHOULDER BOLT, 1/2" X 4" (3/8-16)	1
3.9	F37024	HEX NUT, SELF-LOCKING, 3/8-16	1
3.10	F33006	FLAT WASHER, WIDE, 5/16"	1
4	W1551A	21" PREMIUM PAD DRIVER ASSY	1
4.1	ON216	21" BURNISHING PAD	1
5	W1210	ELECTRIC CLUTCH	1
6	W1220	CLUTCH WASHER	1
7	W2502	PROPANE TNK P#5461TC -20LB.RT	1
8	F0216763	C-LOOP, 1/4"	1
9	MB10	MOTOR SHAFT SPACER	3
10	F58969	6mm X 32mm PARALLEL KEY	1
11	WBX53	V-GROOVE BELT, 5/8" X 53"	1

* ITEMS 1 & 3 ARE INCLUSIVE OF ALL ITEMS BEARING THE RESPECTIVE ITEM NUMBER PREFIX.

** QUANTITIES OF INCLUDED ITEMS ARE AS PER SUBASSEMBLY.

@ ITEM 2 IS DETAILED ON FIRST ILLUSTRATED PARTS SHEET SEPARATELY.

24" & 27" Black Diamond

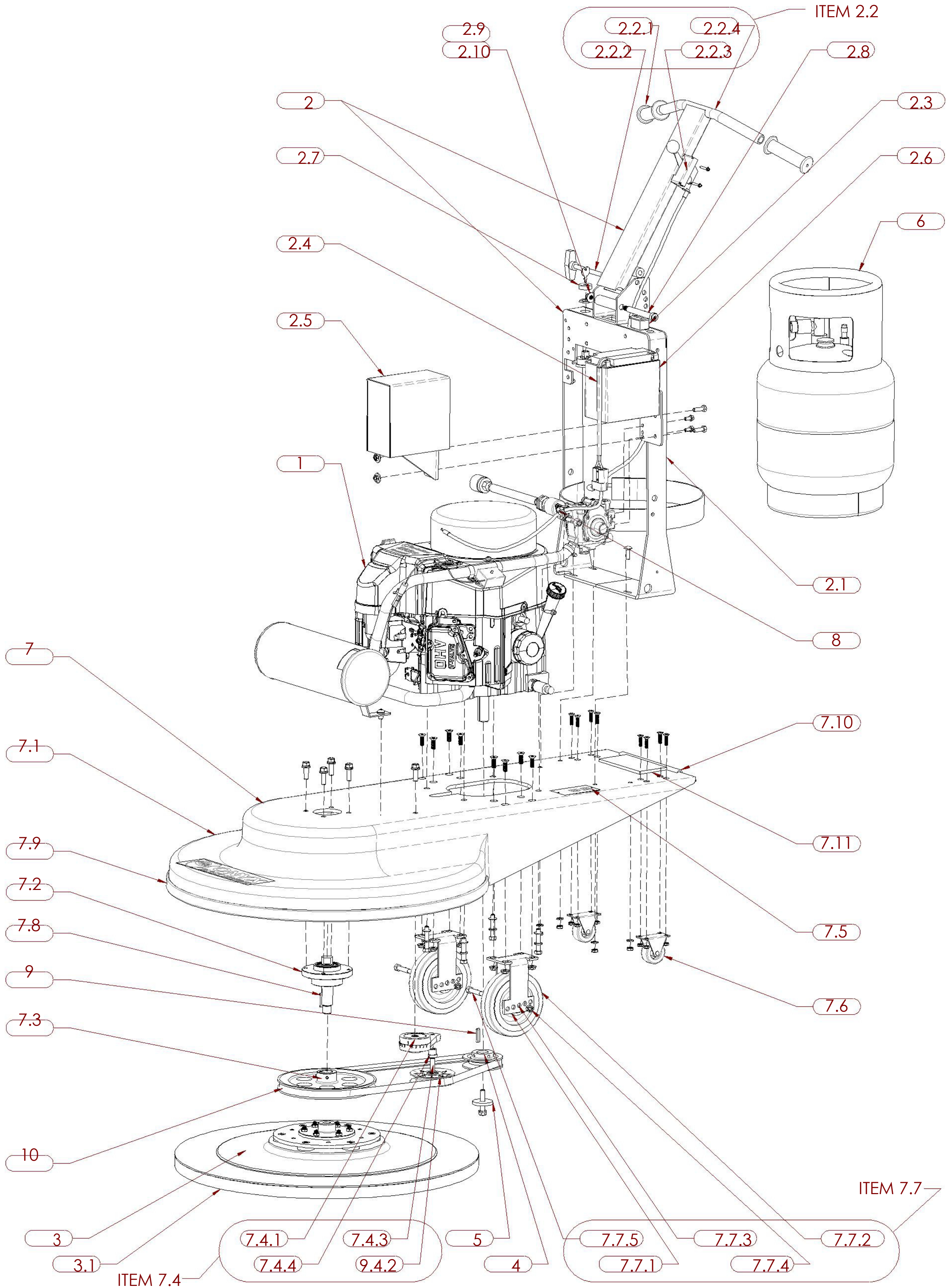

24" & 27" Black Diamond

ITEM NO.	PART NUMBER	DESCRIPTION	QTY 24"	QTY 27"
1	W3102 1B	KAWASAKI FS60018HP12V ASSY	1	1
2	W4057A *	12VBOTTLE CARRIER ASM.	1	1
2.1	W4057	BOTTLE CARRIER - VORTEX	1	1
2.2	W4060-1	I-HANDLE ASSY	1	1
2.2.1	W4050	HANDLE GRIP FOR T-HANDLE	2	2
2.2.2	W1454	T-HANDLE PIN W/ LANYARD, 3/8" X 4"	1	1
2.2.3	W4110	THROTTLE W/ CABLE 53 INCH - WESCON	1	1
2.2.4	W4060	18" T-HANDLE	1	1
2.3	W4312	RECTANGULAR HOUR METFR	1	1
2.4	W1302-1	12V BATTERY & WIRE CONNECTOR	1	1
2.5	W4274	BATTERY BOX	1	1
2.6	W4359	MBTX 12V12A BATTERY	1	1
2.7	W1301	IGNITION SWITCH W/ HARDWARE KEY	1	1
2.8	F26362	SHOULDER BOLT, 1/2" X 4" (3/8-16)	1	1
2.9	F37024	HEX NUT, SELF-LOCKING, 3/8-16	1	1
2.10	F33006	FLAT WASHER, WIDE, 5/16"	1	1
3	W1554A	24" PREMIUM PAD DRIVER ASSY	1	
	W1557A	27" PREMIUM PAD DRIVER ASSY		1
3.1	ON246	24" BURNISHING PAD	1	
	ON276	27" BURNISHING PAD		1
4	W2035	PULLEY, 3 1/2" BK34-1 W/2 SS	1	1
5	W1220	CLUTCH WASHER	1	1
6	W2502	PROPANE TNK P#5461TC -20LB.RT	1	1
7	W5024A *	24" BLACK DIAMOND DECK ASSY	1	
	W5027A	27" BLACK DIAMOND DECK ASSY		1
7.1	W5024-1 *	24" FRAME CAST ALUMINUM	1	
	W5027-1	27" FRAME CAST ALUMINUM		1
7.2	W1060A-1	FRONT END BEARING ASSY	1	1
7.3	W2075	PULLEY 7 1/2" BK77 1 W/2 SS	1	
	W2085	PULLEY 8 3/4" BK90 1 W/2 SS		1
7.4	W1101A-C	ROTARY TENSIONER ASSY	1	1
7.4.1	W1101	ROTARY TENSIONER	1	1
7.4.2	W1102	ROTARY TENSIONER PULLEY	1	1
7.4.3	F13111	HEX BOLT, 3/8-16 X 2"	1	1
7.4.4	W1103	18.7mm x 9.7mm BORE TENSIONER SPACER	1	1
7.5	W1193	NAME PLATE W/ SERIALIZATION	1	1
7.6	W4241	REAR CASTER	2	2
7.7	W4210A **	DLXE WHEEL BRKT ASSY VAC	2	2
7.7.1	W4210	DELUXE WHEEL BRACKET (5 HOLE)	1	1
7.7.2	W4220	RUBBER WHEEL, 6" x 1 1/2"	1	1
7.7.3	W4218	3/8" COLSON WHEEL BUSHING	1	1
7.7.4	F37023	3/8-16 SELF-LOCKING HEX JAM NUT	1	1
7.7.5	W4221	AXLE FOR COLSON WHEEL	1	1
7.8	F58969	6mm X 32mm PARALLEL KEY	1	1
7.9	W4108	27" FRONT BUMPER STRIP	1	1
7.10	MC8507K24	NEOPRENE RUBBER EDCINC	1	1
7.11	MC93625K95	NATURAL GUM FOAM-ADHESIVE	1	1
8	F0216763	C-LOOP, 1/4"	1	1
9	F58969	6mm X 32mm PARALLEL KEY	1	1
10	WB43	V-GROOVE BELT, 5/8" X 43"	1	
	WB51	V-GROOVE BELT, 5/8" X 51"		1

* ITEMS 2 & 7 ARE INCLUSIVE OF ALL ITEMS BEARING THE RESPECTIVE ITEM NUMBER PREFIX.

** QUANTITIES OF INCLUDED ITEMS ARE AS PER SUBASSEMBLY.

@ ITEM 1 IS DETAILED ON FIRST ILLUSTRATED PARTS SHEET SEPARATELY.

24" & 27" Black Diamond with Electric Clutch

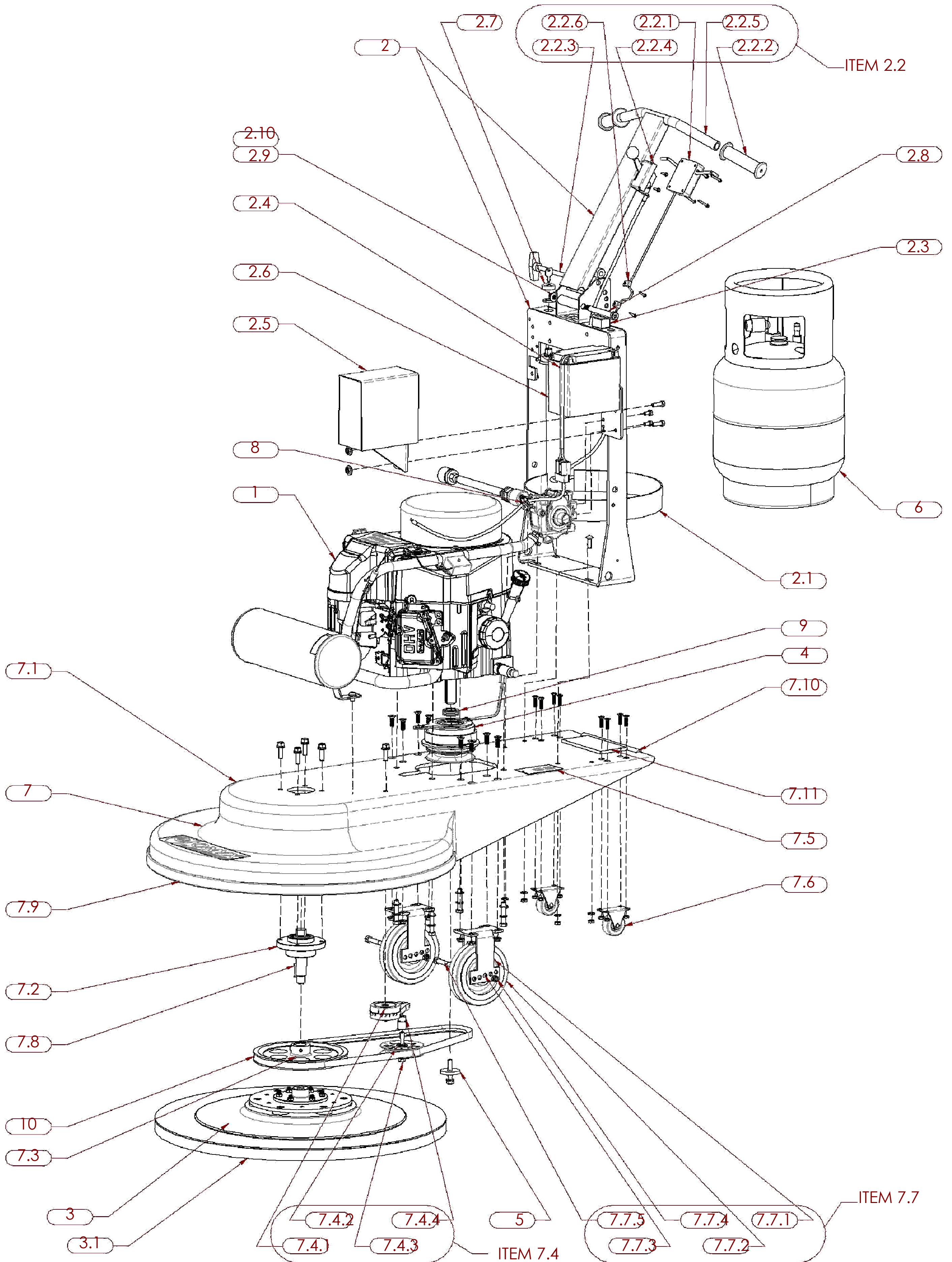

24" & 27" Black Diamond with Electric Clutch

ITEM NO.	PART NUMBER	DESCRIPTION	QTY 24"	QTY 27"
1	W3102-1B	KAWASAKI FS60018HP12V ASSY	1	1
2	W4057A *	12V BOTTLE CARRIER ASM.	1	1
2.1	W4057	BOTTLE CARRIER - VORTEX	1	1
2.2	W4060-1	T-HANDLE ASSY	1	1
2.2.1	W1318A	CLUTCH BOX SWITCH ASSY	1	1
2.2.2	W4050	HANDLE GRIP FOR T-HANDLE	2	2
2.2.3	W1454	T-HANDLE PIN W/ LANYARD, 3/8" X 4"	1	1
2.2.4	W4110	THROTTLE W/ CABLE 53 INCH - WESCON	1	1
2.2.5	W4060	18" T-HANDLE	1	1
2.2.6	F0708750	C-LOOP, 3/16"	2	2
2.3	W4312	RECTANGULAR HOUR MFTFR	1	1
2.4	W1302-1	12V BATTERY & WIRE CONNECTOR	1	1
2.5	W4274	BATTERY BOX	1	1
2.6	W4359	MBTX 12V12A BATTERY	1	1
2.7	W1301	IGNITION SWITCH W/ HARDWARE KEY	1	1
2.8	F26362	SHOULDER BOLT, 1/2" X 4" (3/8-16)	1	1
2.9	F37024	HEX NUT, SELF-LOCKING, 3/8-16	1	1
2.1	F33006	FLAT WASHER, WIDE, 5/16"	1	1
3	W1557A	27" PREMIUM PADD RIVER ASSY	1	1
3.1	ON276	2" BURNISHING PAD	1	1
4	W1210	ELECTRIC CLUTCH	1	1
5	W1220	CLUTCH WASHER	1	1
6	W2502	PROPANE TNK P# 5461TC -20LB.RT	1	1
7	W5024A-C	24" BLACK DIAMOND WITH CLUTCH DECK ASSY	1	
	W5027A-C	27" BLACK DIAMOND WITH CLUTCH DECK ASSY		1
7.1	W5024-1 *	24" FRAME CAST ALUMINUM	1	
	W5027-1	27" FRAME CAST ALUMINUM		1
7.2	W1060A-1 *	FRONT END BEARING ASSY	1	1
7.3	W2085	PULLEY 8 7/8" BK90 X 1 W/2 SS	1	
	W2090	PULLEY 10" BK100 X 1 W/2 SS		1
7.4	W1101A-C	ROTARY CLUTCH TENSIONER ASSY	1	1
7.4.1	W1101	ROTARY TENSIONER	1	1
7.4.2	W1102	ROTARY TENSIONER PULLEY	1	1
7.4.3	13113	HEX BOLT, 3/8-16 X 2 1/2"	1	1
7.4.4	W1104	31.4mm x 9.7mm BORE TENSIONER SPACER	1	1
7.5	W1193	NAME PLATE W/ SERIALIZATION	1	1
7.6	W4241	REAR CASTER	2	2
7.7	W4210A **	DIXIE WHEEL BRKT ASSY VAC	2	2
7.7.1	W4210	DELUXE WHEEL BRACKET (5 HOLE)	1	1
7.7.2	W4220	RUBBER WHEEL, 6" x 1 1/2"	1	1
7.7.3	W4218	3/8" COLSON WHEEL BUSHING	1	1
7.7.4	F37023	3/8-16 SELF-LOCKING HEX JAM NUT	1	1
7.7.5	W4221	AXLE FOR COLSON WHEEL	1	1
7.8	F58969	6mm X 32mm PARALLEL KEY	1	1
7.9	W4108	27" FRONT BUMPER STRIP	1	1
7.1	MC8507K24	NEOPRENE RUBBER EDGING	1	1
7.1.1	MC93625K95	NATURAL GUM FOAM-ADHESIVE	1	1
8	F0216763	C-LOOP, 1/4"	1	1
9	MB10	MOTOR SHAFT SPACER	3	3
10	WBX45	V-GROOVE BELT, 5/8" X 45"	1	
	WBX53	V-GROOVE BELT, 5/8" X 53"		1

* ITEMS 2 & 7 ARE INCLUSIVE OF ALL ITEMS BEARING THE RESPECTIVE ITEM NUMBER PREFIX.

** QUANTITIES OF INCLUDED ITEMS ARE AS PER SUBASSEMBLY.

@ ITEM 1 IS DETAILED ON FIRST ILLUSTRATED PARTS SHEET SEPARATELY.